

# Model 140-B ENGINE CLEANER 6530-0000-1

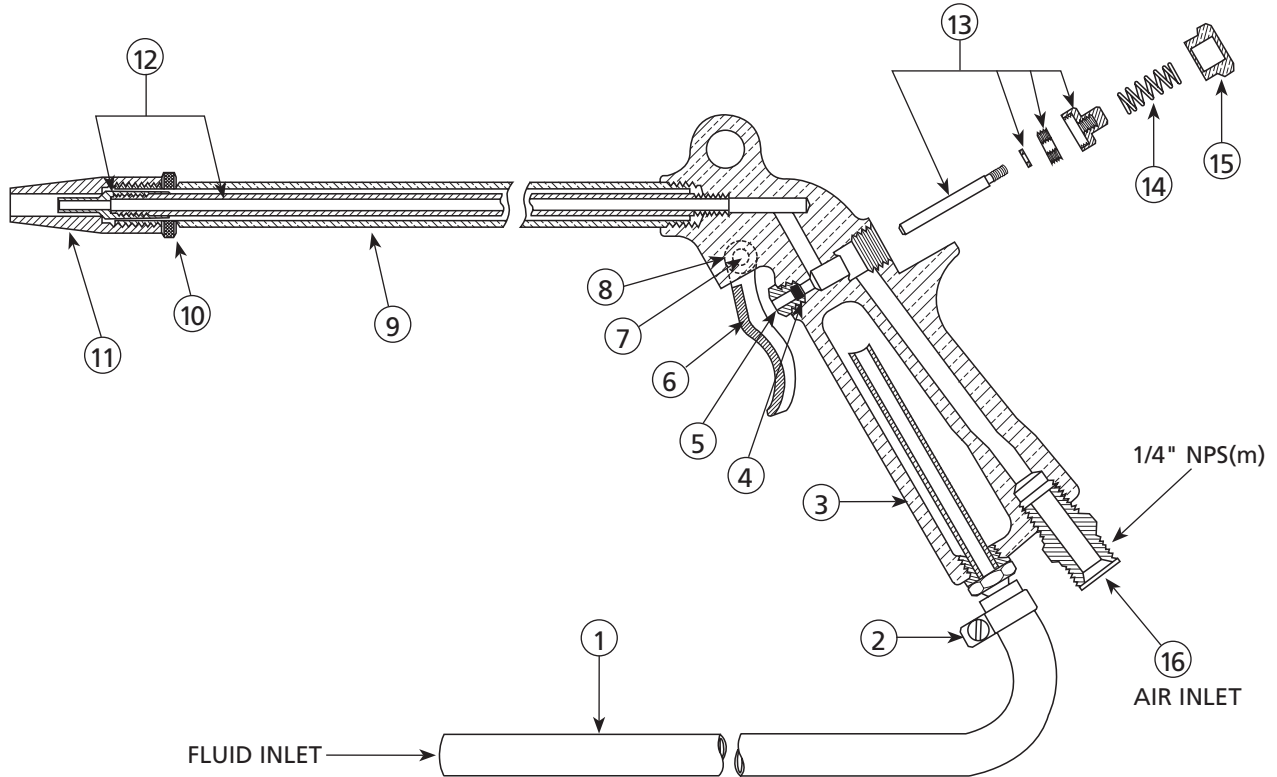

The Binks Model 140B spray gun is used for spraying solvents to clean engines and other machinery. Gun has a brass body with a ten inch nozzle/tube length. Flexible tubing is attached to the gun handle with a hose clamp for

siphoning solvent from container. 1/4" NPS(m) air inlet. Requires 14 CFM air at 50 PSI. Working CFM can range from 8-1/2 to 18-1/2 CFM and from 40 to 100 PSI. Gun weight (less hose): 1.37 lbs.

## PARTS LIST

When ordering, please specify Part No.

ITEM NO.	PART NO.	DESCRIPTION	QTY.	ITEM NO.	PART NO.	DESCRIPTION	QTY.
1	●	SUCTON HOSE 1/4" I.D. x 6' Long...	1	13	57-179	AIR VALVE ASSEMBLY .....	1
2	20-1817■	HOSE CLAMP			57-99■	STEM	
3	57-102■	BODY ASSEMBLY			57-125▲	WASHER	
4	82-158★	PACKING .....	2		58-3	VALVE DISC RETAINER	
5	57-89	PACKING NUT .....	1		58-4	VALVE DISC	
6	57-116	TRIGGER .....	1	14	57-100	AIR VALVE SPRING.....	1
7	57-117▲	TRIGGER SHAFT .....	1	15	57-96★	AIR VALVE CAP .....	1
8	20-2994★▲	E-CLIP .....	2	16	57-13★	AIR CONNECTION .....	1
9	57-93★	OUTSIDE TUBE .....	1				
10	57-8*	NOZZLE LOCK NUT.....	1				
11	57-92*	OUTSIDE NOZZLE .....	1				
12	57-101	AIR TUBE ASSEMBLY .....	1				
	57-94	NOZZLE					
	57-95★	TUBE					

\* Note: To adjust fluid flow, loosen nut (10) and turn nozzle (11).

■ Items NOT available separately.

★ Available from Industrial Finishing distributors only.

▲ Available in Quantity Pak of 5.

● Cut from bulk hose 71-10000 (available from ITW Industrial Finishing distributors).

In this part sheet, the words **WARNING**, **CAUTION** and **NOTE** are used to emphasize important safety information as follows:

**⚠ WARNING**  
 Hazards or unsafe practices which could result in severe personal injury, death or substantial property damage.

**⚠ CAUTION**  
 Hazards or unsafe practices which could result in minor personal injury, product or property damage.

**NOTE**  
 Important installation, operation or maintenance information.

**⚠ WARNING**

Read the following warnings before using this equipment.



**READ THE MANUAL**  
 Before operating finishing equipment, read and understand all safety, operation and maintenance information provided in the operation manual.



**WEAR SAFETY GLASSES**  
 Failure to wear safety glasses with side shields could result in serious eye injury or blindness.



**DE-ENERGIZE, DEPRESSURIZE, DISCONNECT AND LOCK OUT ALL POWER SOURCES DURING MAINTENANCE**  
 Failure to De-energize, disconnect and lock out all power supplies before performing equipment maintenance could cause serious injury or death.



**OPERATOR TRAINING**  
 All personnel must be trained before operating finishing equipment.



**EQUIPMENT MISUSE HAZARD**  
 Equipment misuse can cause the equipment to rupture, malfunction, or start unexpectedly and result in serious injury.



**KEEP EQUIPMENT GUARDS IN PLACE**  
 Do not operate the equipment if the safety devices have been removed.

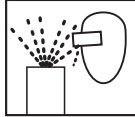

**PROJECTILE HAZARD**  
 You may be injured by venting liquids or gases that are released under pressure, or flying debris.



**PINCH POINT HAZARD**  
 Moving parts can crush and cut. Pinch points are basically any areas where there are moving parts.



**AUTOMATIC EQUIPMENT**  
 Automatic equipment may start suddenly without warning.



**INSPECT THE EQUIPMENT DAILY**  
 Inspect the equipment for worn or broken parts on a daily basis. Do not operate the equipment if you are uncertain about its condition.



**NEVER MODIFY THE EQUIPMENT**  
 Do not modify the equipment unless the manufacturer provides written approval.



**KNOW WHERE AND HOW TO SHUT OFF THE EQUIPMENT IN CASE OF AN EMERGENCY**



**PRESSURE RELIEF PROCEDURE**  
 Always follow the pressure relief procedure in the equipment instruction manual.



**NOISE HAZARD**  
 You may be injured by loud noise. Hearing protection may be required when using this equipment.



**STATIC CHARGE**  
 Fluid may develop a static charge that must be dissipated through proper grounding of the equipment, objects to be sprayed and all other electrically conductive objects in the dispensing area. Improper grounding or sparks can cause a hazardous condition and result in fire, explosion or electric shock and other serious injury.



**FIRE AND EXPLOSION HAZARD**  
 Never use 1,1,1-trichloroethane, methylene chloride, other halogenated hydrocarbon solvents or fluids containing such solvents in equipment with aluminum wetted parts. Such use could result in a serious chemical reaction, with the possibility of explosion. Consult your fluid suppliers to ensure that the fluids being used are compatible with aluminum parts.



**TOXIC FLUID & FUMES**  
 Hazardous fluid or toxic fumes can cause serious injury or death if splashed in the eyes or on the skin, inhaled, injected or swallowed. LEARN and KNOW the specific hazards of the fluids you are using.



**WEAR RESPIRATOR**  
 Toxic fumes can cause serious injury or death if inhaled. Wear a respirator as recommended by the fluid and solvent manufacturer's Material Safety Data Sheet.

**FOR FURTHER SAFETY INFORMATION REGARDING BINKS AND DEVILBISS EQUIPMENT, SEE THE GENERAL EQUIPMENT SAFETY BOOKLET (77-5300).**

**WARRANTY** This product is covered by Binks' 1 Year Limited Warranty.

**Binks Worldwide Sales and Service Listing: [www.binks.com](http://www.binks.com)**

**ITW Industrial Finishing**

Binks has authorized distributors throughout the world. For technical assistance or the distributor nearest you, see listing below.

**U.S./Canada Technical Service Office:**

195 Internationale Blvd., Glendale Heights, IL 60139  
 Toll-Free Telephone: 1-888-992-4657 (U.S.A. and Canada only)  
 Toll-Free Fax: 1-888-246-5732

**DeVilbiss Automotive Refinishing**

DeVilbiss has authorized distributors throughout the world. For equipment, parts and service, check the Yellow Pages under "Automotive Body Shop Equipment and Supplies." For technical assistance, see listing below.

**U.S./Canada Customer Service Office:**

11360 S. Airfield Road, Swanton, OH 43558  
 Toll-Free Telephone: 1-800-445-3988 (U.S.A. and Canada only)  
 Toll-Free Fax: 1-800-445-6643



An Illinois Tool Works Company

77-1191R-7 Revisions: (P2) Updated contact information.