

# SGA Spray Gun

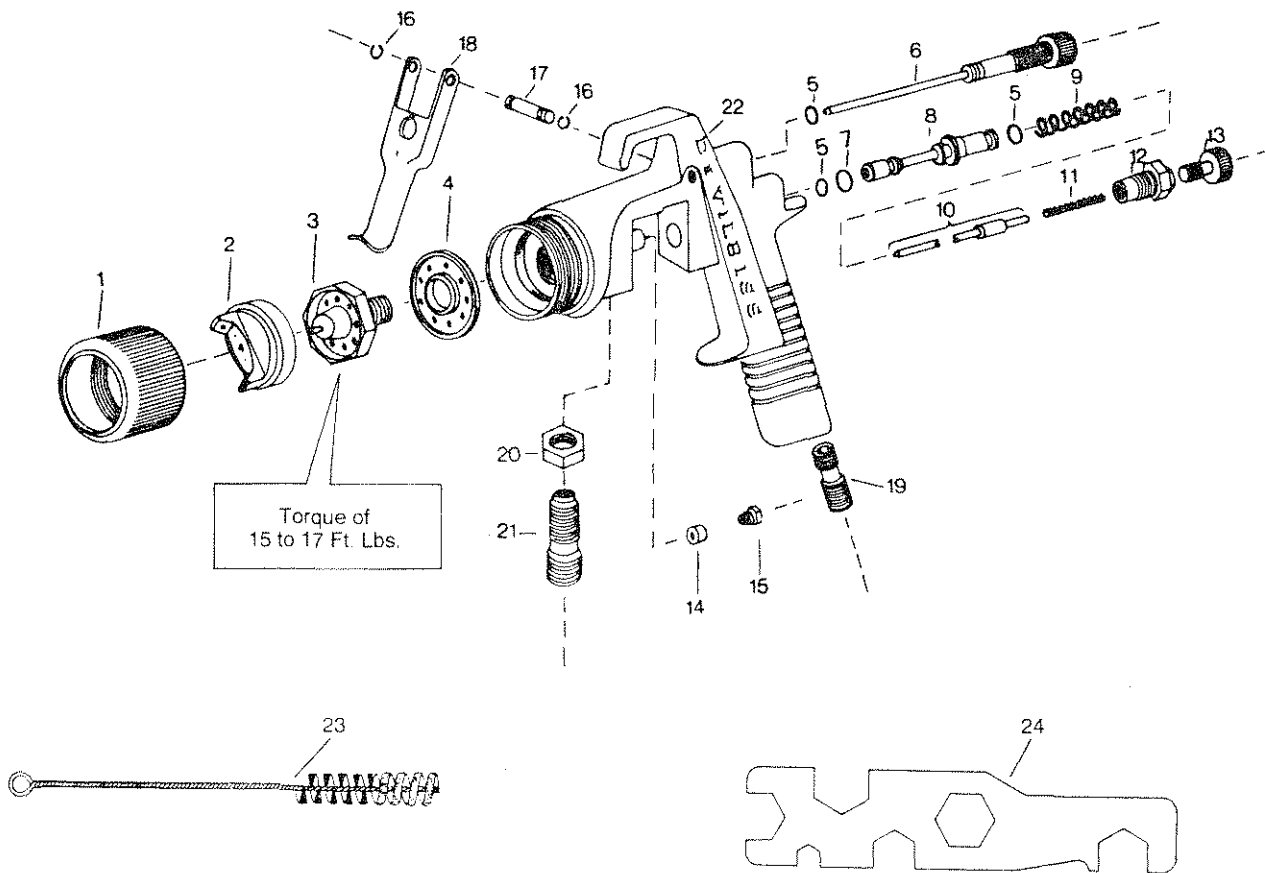

REF.	DeV.	DESCRIPTION
1	BSGB-26	Air cap retaining ring
2	BSGA-3	Air cap
3	BSGA-32	Fluid tip
4	BSGB-5-K5	Baffle
5	BSS-601011-K10	"O" Ring (three)
6	BSGA-412	Valve assembly
7	BSS-601109-K5	"O" Ring
8	BSGA-48	Air Valve
9	BSGA-49-K5	Spring
0	BSGA-404	Fluid needle
11	CGA-40-K5	Spring
12	BSGB-16-K3	Retaining nut
13	BSGB-14	Fluid needle adjusting knob

REF.	DeV.	DESCRIPTION
14	BSGB-15-K5	Packing
15	BSGB-13-K3	Packing nut
16	SST-8416-K10	Retaining ring (two)
17	BSGA-16-K5	Trigger bearing stud
18	BSGA-27	Trigger
19	PTGA-29	Nipple
20	BSGA-37	Lock nut
21	BSGA-40	Fluid adapter
22	BSGA-410	Gun Body
Accessories:		
23	42884-214-K5	Cleaning brush (3/8 Dia.)
	42884-215-K10	Cleaning brush (5/8 Dia.)
24	BSGA-29	Wrench

### Important Note

- The SGA-570 spray gun is a precision tool, designed and manufactured to render high quality finishes.
- In order to maintain its performance characteristics it is important that you carefully follow the instructions herein.

### Application

#### WARNING

CHLORINATED SOLVENTS SUCH AS 111-TRICHLOROETHANE AND METHYLENE IN THIS CHEMICALLY REACT WITH THE ALUMINUM USED IN THIS GUN. THE RESULT OF THIS REACTION CAN RANGE FROM DESTRUCTIVE CORROSION TO A HAZARDOUS EXPLOSION. DO NOT USE THESE SOLVENTS WITH THIS SPRAY GUN.

- The SGA spray gun was developed for use in automobile repair shops and general maintenance work.
- It is adequate for applying all common coating and finishing materials, excepting corrosive, abrasive products and those with very high viscosity.

### How it Works

- The SGA-570 DeVilbiss spray gun works through suction: it draws the material from the cup through a suction tube.
- The pattern is adjusted by the top knob.
- Fluid flow is adjusted by the lower one.

### Installation

For better performance of the DeVilbiss SGA-570 we recommend that:

- The DeVilbiss air filter regulator be installed as close as possible to the spray gun.
- The internal diameter of the DeVilbiss air hose should not be less than 5/16", for a maximum length of 50 feet (15 meters).

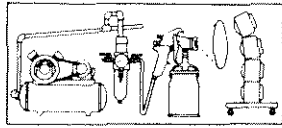

### Operation

#### CAUTION

The air valve assembly (6) is under pressure whenever the gun is triggered. If this valve is turned out too far, it may leave the gun forcefully when the gun is triggered. Also, the "O" ring (5) may be damaged if the valve is turned out past the first thread. Do not turn the valve past the first thread - there will be no effect on the spray pattern after that position.

- Prepare the material which is to be sprayed according to the manufacturer's instructions and filter it through a screen of at least 60 mesh, or equivalent.
- Set the air pressure at the DeVilbiss filter regulator to about 35 p.s.i. to start.
- Effect a spray test.
- Spray a test pattern. Regulate the fan by opening or closing its adjusting knob.
- Spray a small area in order to achieve the desired job speed and finish.
- If the finish appears to be dry or rough, the quantity of material is small in relation to the air pressure. Open the fluid regulating knob, or decrease the air pressure in the DeVilbiss filter regulator until you achieve a wet and full coating.
- Keep the spray gun always perpendicular to the surface which is to be painted.
- Do not arc the gun as this produces an uneven coat of paint.
- We recommend the spray gun be kept at a distance of 6 to 8 inches from the surface.
- The position of the air cap determines the position of the pattern. Twist the cap according to spraying requirements.

### Cleaning

We recommend that the spray gun be cleaned daily, or after each time the equipment is used.

### Procedure

- Remove the cup. Empty the remaining material from the cup and refill it with about one inch of suitable solvent.
- Put cup back on gun and shake same.
- Pull the trigger for a while.
- Loosen the cup again and clean it inside with a cloth using the remaining solvent. Clean also the lid and suction tube.
- Repeat the flushing procedure at least once again.
- Wipe the exterior of the gun with a solvent dampened cloth.
- If necessary, remove the air cap and clean it by immersing same in solvent. If the holes have clogged use a toothpick to remove the obstruction. Never use wires or nails, as this could ruin the air cap.
- Never immerse the spray gun in solvent since this destroys the lubricants and packings.

### Lubrication

- Lubricate daily with thin oil the trigger bearing stud (17), the fluid needle (10), close to the packing (14), the threads of the valve assembly (6) and the exposed part of the air valve (8).
- Periodically cover the springs of the needle (11) and of the air valve (9) with vaseline or thin grease.

### When to change the tip and needle

The tip and needle should be replaced when:

- There occurs wear of the tip, of the needle or the seat of the tip.
- There are signs of wear on the needle at the point of contact with the packing.
- Never replace only the fluid tip (3) or the needle (10). Always change both of them.
- The tip should be screwed on carefully in order not to hurt the thread of the gun body. Tighten it for a good sealing, but never over-tighten it. Always use the DeVilbiss BSGA-29 wrench. Always tighten the fluid tip before assembling the needle into the gun body.
- The tip should be screwed on carefully in order not to hurt the thread of the gun body. Tighten it for a good sealing, but never over-tighten it. Always use the DeVilbiss BSGA-29 wrench. Always tighten the fluid tip with a torque of 15 to 17 Ft.Lbs. before assembling the needle into the gun body.
- Always replace the packing (14) when you assemble a new set of tip and needle. Lubricate the new packing before assembly.
- The packing nut (15) should be just tight enough and not hinder the free movement of the needle.







### REPAIR KITS

K-5001			K-5004		
QTY.	DeV.	DESCRIPTION	QTY.	DeV.	DESCRIPTION
1	BSGA-32	Fluid tip	1	BSGB-15	Packing
1	BSGA-404	Fluid needle	3	BSS-601011	"O" Ring
2	BSGB-15	Packing	1	BSS-601109	"O" Ring
1	BSGB-5	Baffle	1	BSGA-49	Spring
			1	CGA-40	Spring
			1	BSGA-16	Trigger pin
			2	SST-8416	Snap ring

### HOW TO REQUEST REPLACEMENT PARTS

When requesting replacement parts always give the : 1. Kit or Part Code-2. Description of same - 3. Type of spray gun.

### SERVICE CHECKS

Condition	Cause	Correction
 Top/or bottom heavy pattern.	1. Material build up on air cap. 2. Partially plugged horn holes, center hole or jets.	1. Remove cap and soak it in suitable solvent and wipe clean. (See Cleaning) 2. Same as above. 3. Remove fluid tip and clean same with solvent.
 Heavy right or left side pattern.	3. Material partially plugged fluid tip. 4. Damaged fluid tip.	4. Replace tip and needle set. (See When to Change the Tip and Needle).
 Heavy center pattern.	1. Too much material. 2. Material too thick.	1. Reduce fluid flow by turning needle adjusting knob clockwise or increase air pressure in the DeVilbiss filter regulator. 2. Thin material.
 Split spray pattern.	1. Pressure is too high. 2. Not enough material.	1. Reduce air pressure of the DeVilbiss filter regulator. 2. Increase fluid flow by turning fluid needle adjusting knob counterclockwise.
 Jerky or fluttering spray.	1. Insufficient fluid in cup. 2. Gun and cup tipped at excessive angle. 3. Obstructed fluid passage. 4. Loose or cracked fluid tube in cup. 5. Loose fluid tip or cracked fluid tip seat. 6. Too heavy fluid for suction feed. 7. Dry or worn packing (14) or loose packing nut (15)	1. Fill cup. 2. Do not tip excessively or rotate fluid tube in cup. 3. Clean same. 4. Tighten or replace same. 5. Tighten or replace the tip and needle set. 6. Thin material. 7. Lubricate or replace packing or tighten packing nut.
 Will not spray	1. Low air pressure at gun. 2. Closed fluid adjusting knob. 3. Too heavy fluid for suction feed. 4. Loose air cap.	1. Check air lines or increase pressure at DeVilbiss air filter regulator. 2. Open same. (See Operation). 3. Thin material. 4. Tighten same.
 Dripping from fluid tip.	1. Worn or damaged tip or needle.	1. Replace tip and needle set. (See When to Change Tip and Needle)