

**INDUSTRIAL COATING EQUIPMENT**

**JGA SPRAY GUN**

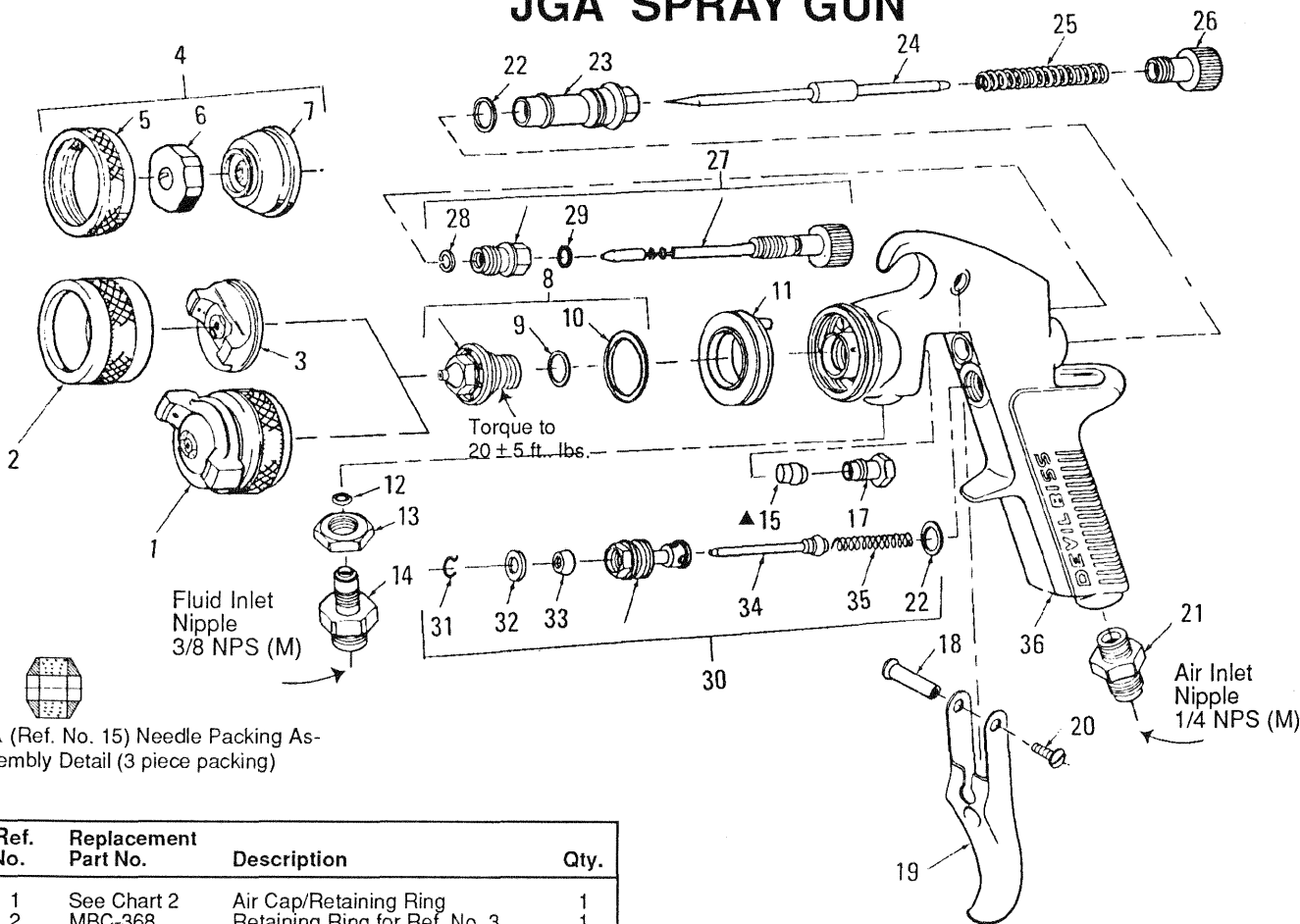

▲ (Ref. No. 15) Needle Packing Assembly Detail (3 piece packing)

**WARNING**

Halogenated hydrocarbon solvents— for example: 1,1,1- trichloroethane and methylene chloride— can chemically react with the aluminum in this gun and cause an explosion hazard. Read the label or data sheet for the material you intend to spray. Do not use spray materials containing these solvents with this spray gun.

**DESCRIPTION**

**JGA-502** Standard spray gun, has hardened alloy steel fluid tip, stainless steel fluid needle and brass baffle.

**JGA-5401** Quick-purging spray gun, has restricted fluid passage, stainless steel fluid tip, fluid needle and brass baffle. Most suited for recirculating systems.

**Important:** Before using gun, tighten packing nut until the needle starts to bind. Then, loosen nut just enough so the needle moves freely.

**PREVENTIVE MAINTENANCE**

Strain material thru 60 or 90 mesh screen.

To clean gun passages, blow back paint to material source and flush fluid passage with clean solvent. Wipe gun clean with solvent soaked cloth.

To clean air cap, soak in thinner, brush with a stiff brush. If necessary, use a broom straw or toothpick. Never use a wire or hard instrument, this may scratch or burr holes causing a distorted spray pattern.

Ref. No.	Replacement Part No.	Description	Qty.
1	See Chart 2	Air Cap/Retaining Ring	1
2	MBC-368	Retaining Ring for Ref. No. 3	1
3	See Chart 2	Air Cap Less Retaining Ring	1
4	See Chart 2	Air Cap, Adapter/Retaining Ring	1
5	MB-290	Retaining Ring for Ref. No. 7	1
6	See Chart 2	Air Cap	1
7	33625-122	Adapter for 31733-490 Air Cap	1
	33625-124	Adapter for 31736-491 Air Cap	1
8	See Chart 3	Fluid Tip and Gasket	1
9	SS-7312-K5	Gasket Kit for JGA-5401 Only	1
* 10	AV-1-K5	Gasket Kit	1
11	JGA-1225	Baffle	1
* 12	23165-001-K5	O-Ring for JGA-502 Only	1
13	JGA-51-K5	Lock Nut Kit	1
14	P-JGA-2-2	Nipple for JGA-502	1
	P-JGA-73	Nipple for JGA-5401 (See Accessories)	1
* 15	JGA-4035-K3	Packing Kit	1
16	—	Not Used	—
17	34411-122-K3	Packing Gland Kit	1
* 18	JGS-35-K5	Trigger Bearing Stud Kit	1
19	JGS-108	Trigger	1
* 20	A-42-K5	Screw Kit	1
21	P-MB-51	Nipple	1
* 22	JGS-72-K10	Gasket Kit	2
23	JGA-17	Bushing	1
24	See Chart 3	Fluid Needle	1
* 25	MBD-19-K5	Spring Kit	1
26	JGS-16	Adjusting Screw	1
27	JGA-4004	Fan Adjustment Assembly	1
* 28	SST-8405-K5	Retaining Ring Kit	1
* 29	SSG-8020-K5	O Ring Kit	1
30	JGS-449	Air Valve Assembly	1
* 31	JGA-14-K5	Snap Ring Kit	1
* 32	JGA-15-K5	Washer Kit	1
* 33	JGS-26-K5	U Cup Seal	1
* 34	JGS-431	Air Valve	1
* 35	MBD-12-K5	Spring Kit	1
36	JGA-401-2	Gun Body (For JGA-502 Only)	1
#37	See Chart 3	Lapped Tip, Needle and Gasket Assembly for JGA-502 Only (Not shown)	1

\* A quantity of necessary parts is included in repair kit KK-4830 for complete gun repair. Suffixes - K5, K3, K-10 designated kits of multiple parts. (Example) AV-1-K5 is a kit of 5 gaskets.  
 # Ref. No. 37 includes Ref. Nos. 8, 10 and 24.

**Note**

When replacing the fluid tip or fluid needle, replace both at the same time. Using worn parts can cause fluid leakage. Lapped sets are available for most pressure feed combinations. See Chart 3. Lapped sets are particularly recommended with thinner, less viscous materials. Also, replace the fluid tip gasket and needle packing at this time. Lightly lubricate the threads of the fluid tip before reassembling. Torque to 20 ± 5 ft. lbs. Do not over tighten.

**Spray Gun Lubrication**

For best results, lubricate the points indicated, daily. Use SSL-10 Spray Gun Lube to lubricate.

- A. Trigger Points
- B. Packing
- C. Adjusting Valve

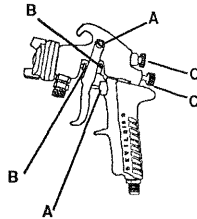

- Not for air tools or high RPM equipment.

**JGA-4035-K3 Packing Replacement Instructions**

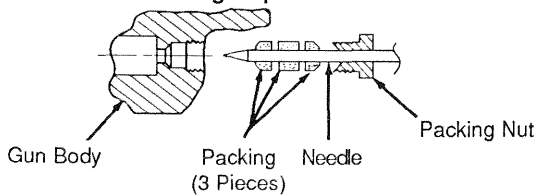

1. Remove adjusting knob and needle spring from gun.
2. Partially withdraw needle from gun body.
3. Remove old packing.
4. Assemble packing nut to needle.
5. Assemble packing in order shown to needle.
6. Insert needle all the way into gun body seating in tip.
7. Install needle spring and adjusting knob.
8. Thread packing nut into gun body.
9. Tighten packing nut in equal increments — no more than 1/6 turn.
10. After each adjustment, pull needle open and observe needle closure.
11. If needle snaps shut, continue adjusting nut until there is evidence of needle bind or slow closing.
12. Back off packing nut 1/12 turn to the point where needle snaps shut. Packing nut must remain tight enough to prevent loosening by hand.
13. Pull needle several times to verify needle snaps shut, and check packing nut for looseness.

**CHART 1**

Models		Air Cap Sizes Order From Chart 2	Fluid Tip and Needle Sizes Order From Chart 3							
JGA-502	JGA-5401		D	E	EE	EX	FF	FX	FZ	G
•	•	24	P	P				P		
•	•	30		P		S	P	P		
•	•	43				S	P			
•	•	58		P		S	P	P		
•	•	78		P			P	P	P	
•	•	80				S				
•	•	264					P			
•	•	490		P			P	P		
•	•	491	P							
•	•	704		P			P	P		
•	•	705		P			P	P		
•	•	765		P			P	P	P	
•	•	770					P	P		
•	•	797		P			P	P		P

P— Pressure Feed Combination  
S— Suction Feed Combination

**CHART 2**

Air Caps		
No. on Cap Order →	Ref. Nos. 1 and (4) Air Cap With Ring	Ref. Nos. 3 and (6) Air Cap Less Ring
24		AV-40-24
30	MB-4039-30	
43		31767-043
58	AV-439-58	
67	MB-4039-67	
69	MB-4039-69	
78	MB-4039-78	
80	MB-4039-80	
264		31767-264
**490		31733-490
**491		31736-491
704		AV-1239-704
705		AV-1239-705
765		AV-1239-765
770		AV-1239-770
797		AV-1239-797

\*\*— Internal Mix

**CHART 3**

Fluid Tips and Needles			
If this is No. on Tip Order →	*Ref. No. 8 Fluid Tip & Gasket Assy.	Ref. No. 24 Fluid Needle No. on Needle	Ref. No. 37 Lapped Tip & Needle Assy.
JGA-502			
hyten		ss	
AV-15-D	AV-650-D	JGA-402-DEX	JGA-4040-D
AV-15-E	AV-650-E	JGA-402-E	JGA-4040-E
AV-15-EX	AV-650-EX	JGA-402-DEX	None
AV-15-FF	AV-650-FF	JGA-402-FF	JGA-4040-FF
AV-15-FX	AV-650-FX	JGA-402-FX	JGA-4040-FX
AV-15-FZ	AV-650-FZ	JGA-402-FZ	JGA-4040-FZ
AV-15-G	AV-650-G	JGA-402-G	None
JGA-5401			
ht-rstd		ss	
AV-1715-FF	AV-489-FF	JGA-402-FF	None

ss- Stainless Steel  
ht-rstd- Hyten-restricted

**ACCESSORIES**

**P-JGA-459 FLUID INLET NIPPLE**— Optional nipples for JGA-5401 with built-in metering valve for adjusting fluid flow.

**VS-531 LOW PRESSURE FLUID STRAINER**—The VS-531 Low Pressure Fluid Strainer provides a final filter for trapping foreign particles in the paint supply.

**P-H-5516 ADJUSTING AIR VALVE**— Enables user to control and reduce air usage at the gun. Ideal for low pressure spraying.

**42884-214-K5 3/8" CLEANING BRUSH**

**42884-215-K10 5/8" CLEANING BRUSH**— These brushes are helpful in cleaning threads and recesses of gun body.

**HD-503 HOSE CLEANER**— Hose cleaner used to clean the inside of hose and material passages of gun.

**JGA-408-2 NYLON BAFFLE** Use in place of brass baffle. Do not use AV-1 gasket with this nylon baffle.

**WR-103 WRENCH**— Contains all necessary tip, hose and nut sizes used on or with gun.

**41677-205 (FX) 41677-206 (FF) RESILIENT TIPPED NEEDLE**— Suited for use with organic finishing materials and many wood sealers containing silica.

**SSL-10 SPRAY GUN LUBE (2oz. bottle)**— Compatible with all paint materials: contains no silicone or petroleum distillates to contaminate paint.

**HAV-501 AIR ADJUSTING VALVE**— Use to control air usage at gun.

**HARG-510 AIR REGULATOR**— Use to maintain constant outlet pressure despite changes in inlet pressure and downstream flow.

**SERVICE NOTES**

This product is covered by DeVilbiss' Limited 1 Year Warranty. See SB-1-000 which is available upon request.

For complete guide on air spray equipment, order free Service Bulletin SB-2-001.

For a list of Authorized Warranty Service Centers, request latest Service Reference SR-1-20-1.