

MODEL 570 AUTOMATIC MASTIC AIRLESS SPRAY GUN

6700-0000-7 FOR PROFESSIONAL USE ONLY



WARNING — HIGH PRESSURE — WARNING

MAXIMUM WORKING PRESSURE UP TO 4000 POUNDS PER SQUARE INCH

- DO NOT POINT SPRAY GUN AT ANY PART OF THE HUMAN BODY
- FLUID UNDER HIGH PRESSURE CAN PENETRATE THE SKIN AND CAUSE SEVERE INTERNAL INJURY
- IN CASE OF INJURY OBTAIN MEDICAL ATTENTION IMMEDIATELY
- BE SURE TO REPORT NATURE OF INJURY AND TYPE OF FLUID OR SOLVENT TO THE DOCTOR

Be sure you understand ALL of the following instructions thoroughly BEFORE operating any part of the airless equipment system. CONSULT YOUR BINKS REPRESENTATIVE TO CLEAR UP ANY ITEMS OF INSTRUCTION YOU DO NOT UNDERSTAND.

1. UNDER NO circumstances should the spray gun be carelessly handled nor its spray (even when the nozzle is removed) directed at close proximity to any part of the human body.
2. DO NOT operate airless spray gun with tip guard housing removed or altered.
3. NEVER clean, change, or remove the nozzle from the spray gun without first doing the following:
 - a. Shut off pump and, in addition, unplug electrical cord or turn off air supply.
 - b. Release fluid pressure in the entire system, from pump or supply line to spray gun.
4. NEVER attempt to force the flow of liquid backward through the gun (blowback) with your finger, hand, or hand-held object pressed against the gun nozzle.
5. NEVER plug a hose leak with your finger, with adhesive tape, or other “stop-gap” device.
6. NEVER operate the airless system with a defective hose. ALWAYS replace the defective hose immediately. For continuing safety, users are urged to:
 - a. ALWAYS handle carefully all hose connections, joints, and seating surfaces on the spray gun to prevent damage.
 - b. NEVER kink or bend the fluid hose into less than a four inch radius.
 - c. FREQUENTLY check the hose for kinks or abrasions. These may develop into a rupture.
 - d. NEVER use standard hardware to modify the airless system. ALWAYS use Binks high pressure fittings only.
7. The airless pump must be grounded before operating the airless spray system.

INSTALLATION AND OPERATING INSTRUCTIONS

Your new Binks 570 Automatic Airless Spray Gun has been thoroughly tested before leaving the factory. No adjustments are required before spray operations begin other than installing the nozzle tip selected. The gun body has four holes which allow the material body to be mounted in any of four positions for convenient fluid hose hookup.

The following steps are recommended for obtaining best results from your spray gun:

1. Install spray gun on gun mount and tighten the set screw (9) securely. **Note:** The mounting hole is 1/2" diameter.
2. Connect air hose to fitting (16). The gun is actuated by air pressure from a 3-way valve. The valve provides air to trigger, shut-off, and exhausts air from the gun. The gun should be limited to 200 cycles per minute (maximum). Approximately 40 to 60 psi air pressure is required to operate the spray gun; however, use the minimum air pressure required.
3. Connect high pressure airless fluid hose to the gun material body assembly (7) and tighten.
4. Remove tip guard assembly (4), nozzle tip, and gasket (3) from spray gun (or remove Twist-Tip if used).

Turn on air supply to operate air valve to spray gun. Turn on material supply very slowly and allow spray gun to trigger a few times to purge any entrapped air in fluid system.

5. Shut fluid supply and air supply OFF.
6. Replace gasket (3), nozzle tip, and tip guard assembly (4) (or Twist-Tip) as per safety procedure described in paragraph 3 above.
7. Turn air and fluid supply ON and check the spray pattern for proper atomization.
8. The spray gun nozzle should be located at such a dis-

NOTE

When the pattern is right, the pressure is right. Excessive fluid pressure will only distort the spray pattern.

tance to the product where maximum fan pattern width is evident. This is usually 8" to 14". The spray pattern may be positioned either vertically or horizontally by rotating nozzle tip (or the Twist-Tip).

continued on pg. 3

In this part sheet, the words **WARNING**, **CAUTION** and **NOTE** are used to emphasize important safety information as follows:

WARNING

Hazards or unsafe practices which could result in severe personal injury, death or substantial property damage.

CAUTION

Hazards or unsafe practices which could result in minor personal injury, product or property damage.

NOTE

Important installation, operation or maintenance information.

WARNING

Read the following warnings before using this equipment.



READ THE MANUAL

Before operating finishing equipment, read and understand all safety, operation and maintenance information provided in the operation manual.



OPERATOR TRAINING

All personnel must be trained before operating finishing equipment.



EQUIPMENT MISUSE HAZARD

Equipment misuse can cause the equipment to rupture, malfunction, or start unexpectedly and result in serious injury.



LOCK OUT / TAG-OUT

Failure to de-energize, disconnect, lock out and tag-out all power sources before performing equipment maintenance could cause serious injury or death.



AUTOMATIC EQUIPMENT

Automatic equipment may start suddenly without warning.



PRESSURE RELIEF PROCEDURE

Always follow the pressure relief procedure in the equipment instruction manual.



KEEP EQUIPMENT GUARDS IN PLACE

Do not operate the equipment if the safety devices have been removed.



KNOW WHERE AND HOW TO SHUT OFF THE EQUIPMENT IN CASE OF AN EMERGENCY



WEAR SAFETY GLASSES

Failure to wear safety glasses with side shields could result in serious eye injury or blindness.



INSPECT THE EQUIPMENT DAILY

Inspect the equipment for worn or broken parts on a daily basis. Do not operate the equipment if you are uncertain about its condition.



NEVER MODIFY THE EQUIPMENT

Do not modify the equipment unless the manufacturer provides written approval.



NOISE HAZARD

You may be injured by loud noise. Hearing protection may be required when using this equipment.

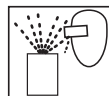

PROJECTILE HAZARD

You may be injured by venting liquids or gases that are released under pressure, or flying debris.



PINCH POINT HAZARD

Moving parts can crush and cut. Pinch points are basically any areas where there are moving parts.



STATIC CHARGE

Fluid may develop a static charge that must be dissipated through proper grounding of the equipment, objects to be sprayed and all other electrically conductive objects in the dispensing area. Improper grounding or sparks can cause a hazardous condition and result in fire, explosion or electric shock and other serious injury.



WEAR RESPIRATOR

Toxic fumes can cause serious injury or death if inhaled. Wear a respirator as recommended by the fluid and solvent manufacturer's Safety Data Sheet.



TOXIC FLUID & FUMES

Hazardous fluid or toxic fumes can cause serious injury or death if splashed in the eyes or on the skin, inhaled, injected or swallowed. LEARN and KNOW the specific hazards of the fluids you are using.



FIRE AND EXPLOSION HAZARD

Improper equipment grounding, poor ventilation, open flame or sparks can cause a hazardous condition and result in fire or explosion and serious injury.



MEDICAL ALERT

Any injury caused by high pressure liquid can be serious. If you are injured or even suspect an injury:

- Go to an emergency room immediately.
- Tell the doctor you suspect an injection injury.
- Show the doctor this medical information or the medical alert card provided with your airless spray equipment.
- Tell the doctor what kind of fluid you were spraying or dispensing.



GET IMMEDIATE MEDICAL ATTENTION

To prevent contact with the fluid, please note the following:

- Never point the gun/valve at anyone or any part of the body.
- Never put hand or fingers over the spray tip.
- Never attempt to stop or deflect fluid leaks with your hand, body, glove or rag.
- Always have the tip guard on the spray gun before spraying.
- Always ensure that the gun trigger safety operates before spraying.



CA PROP
65

PROP 65 WARNING

WARNING: This product contains chemicals known to the State of California to cause cancer and birth defects or other reproductive harm.

IT IS THE RESPONSIBILITY OF THE EMPLOYER TO PROVIDE THIS INFORMATION TO THE OPERATOR OF THE EQUIPMENT. FOR FURTHER SAFETY INFORMATION REGARDING THIS EQUIPMENT, SEE THE GENERAL EQUIPMENT SAFETY BOOKLET (77-5300).

Binks reserves the right to modify equipment specification without prior notice.

Binks MODEL 570 AUTOMATIC MASTIC AIRLESS SPRAY GUN

9. "Hour glass" or "tails" on the spray pattern normally indicates too low a fluid pressure for the nozzle tip being used; or, the material is too viscous.
10. A distorted spray pattern usually means a plugged or worn nozzle tip.
11. Using excessive fluid pressure will only cause undue wear of the nozzle tip.

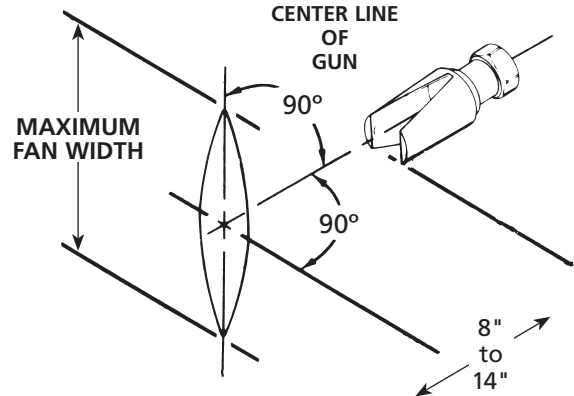
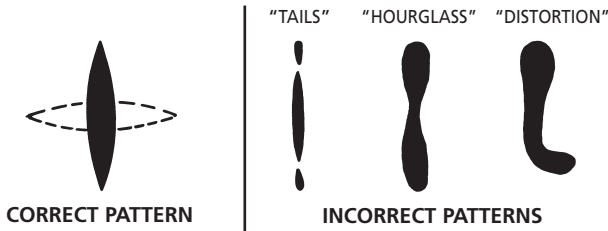

MAINTENANCE INSTRUCTIONS

(See High Pressure Warning Statement on Page 1)

To Clean Nozzle Tip:

1. BEFORE proceeding with any maintenance, read safety procedure, paragraph 3, in High Pressure Warning, page 1.
2. Remove tip guard assembly (4), nozzle tip, and gasket (3).
3. Submerge nozzle tip in solvent to remove dried material.
4. Blow air through nozzle tip to clean.
5. Airless spray nozzle Tips are made of tungsten carbide and are very brittle. Do not drop. To clean a nozzle tip use solvent, toothpick or sharpened match. Never use a metal probe.

To Replace Wire Assembly:

1. BEFORE proceeding with any maintenance, read safety procedure, paragraph 3, in High Pressure Warning, page 1.
2. For convenience, you may wish to remove spray gun from gun mount.

3. Carefully remove the cap (10). The spring (13) is under tension and will come out when cap (10) is removed.
4. Remove nut (14) and lockwasher (15). The back plate (12), diaphragm (11) and washer (17) may be removed at this time.
5. Loosen the wire assembly nut (6) from the stem (20).
6. Loosen and remove the bearing screw assembly (19) and the stem (20) from spray gun. The packing (18) should also be inspected at this time. If worn, replace.
7. Loosen and remove the gland nut (21). The wire assembly (6) may now be pulled rearward from the spray gun.
8. If worn, replace the gland set (22).
9. The material body assembly (7) may be removed for cleaning by loosening set screws (1). Note the pin in gun body assembly (8).
10. Reassemble in reverse order.

DIFFUSER ASSEMBLIES*

Reduces fluid velocity to minimize tip wear and to aid fluid filtration. 54-2229 nylon gasket is included with 54-2378.

54-2378 nut for use with 54-1835 (.005) or 54-1836 (.009) edge type filter.



54-1640 54-1639 54-2378 54-1835
54-1797 54-1836

*Not furnished.
Please order separately.

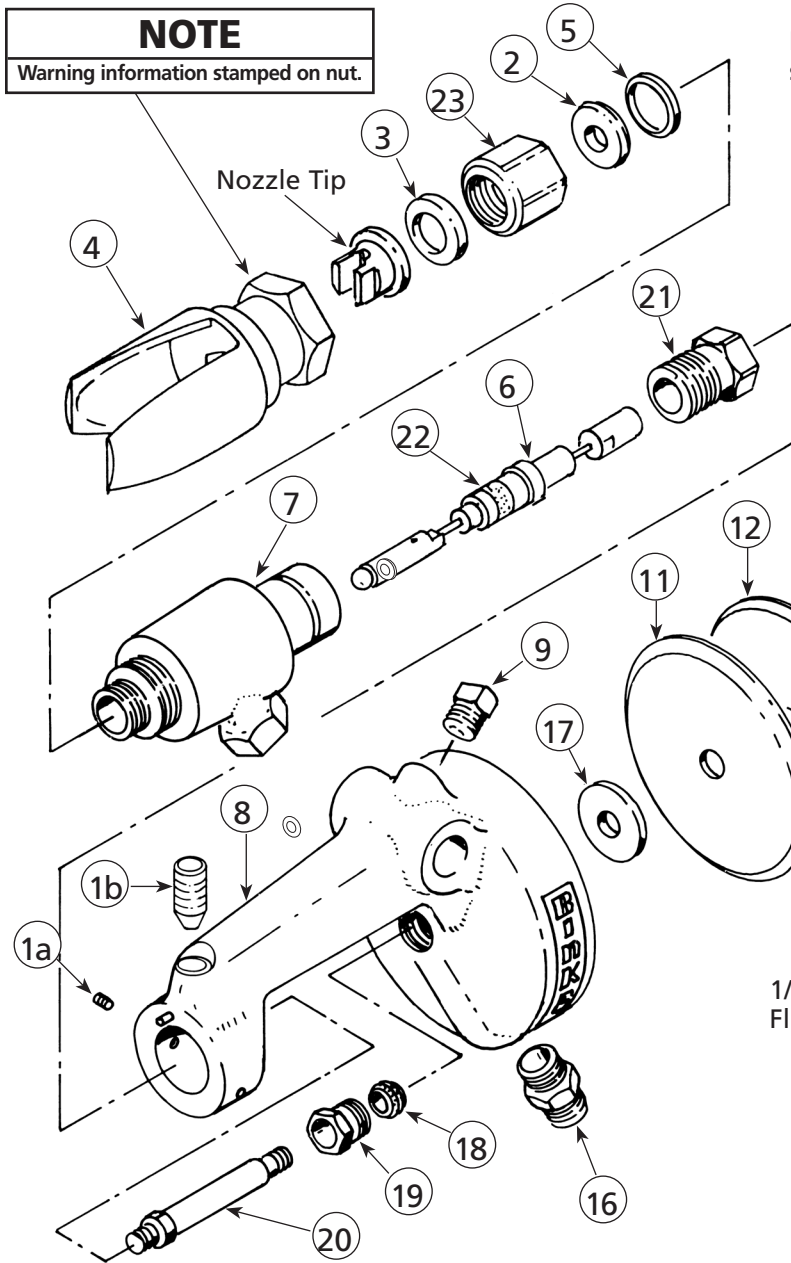

NOZZLE TIP not furnished. Please order separately. See page 5 for selections.

NOTE
 Keep gland nut (21) tight at all times. Should leak occur at gland nut (21), replace gland set (22). Wire assembly (6) will be damaged if leak persists.

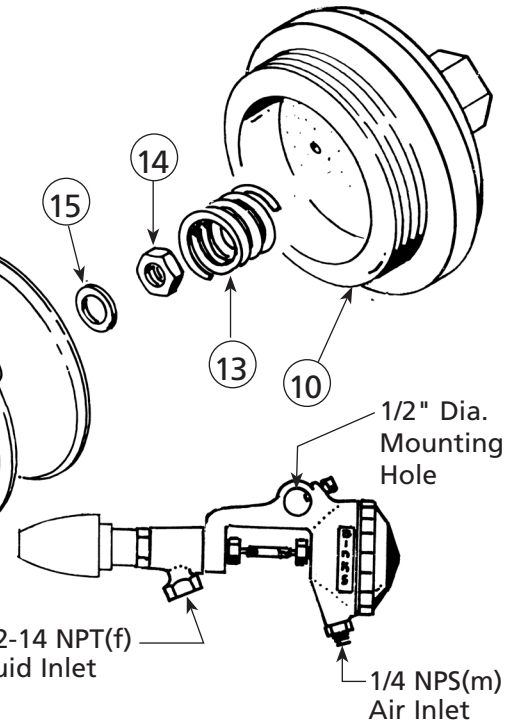

PARTS LIST

(When ordering, please specify Part No.)

ITEM NO.	PART NO.	DESCRIPTION	QTY.	ITEM NO.	PART NO.	DESCRIPTION	QTY.
1a	—	SET SCREW 1/4-20 x 3/16" Long.....	2	11	54-3051†	DIAPHRAGM	1
1b	—	SET SCREW 1/4-20 x 1/2" Long, with Nylock.....	1	12	54-3054	BACK PLATE	1
2	54-2929†	SEAT.....	1	13	54-3052†	SPRING.....	1
3	54-2229†	GASKET	1	14	—	NUT 8/32	1
4	54-3085	TIP GUARD ASSEMBLY	1	15	—	LOCKWASHER.....	1
5	54-2927†	SEAL.....	1	16	71-28	FITTING 1/8 NPT x 1/4 NPS.....	1
6	54-2955†	WIRE ASSEMBLY.....	1	17	54-3055	WASHER	1
7	54-3048	MATERIAL BODY ASSEMBLY.....	1	18	54-3053†	PACKING.....	1
8	—	GUN BODY ASSEMBLY	1	19	54-3059	BEARING SCREW ASSEMBLY.....	1
9	20-1359	SET SCREW 5/16-18 x 5/8" Long.....	1	20	54-3061	STEM.....	1
10	54-3060	CAP ASSEMBLY	1	21	54-2964	GLAND NUT	1
				22	54-2949*	GLAND SET.....	1
				23	54-2928	SET CAP.....	1

† Also available in 54-3122 Repair Kit. Please order separately.
 * Furnished with Wire Assembly (6).

BINKS TWIST-TIP REVERSIBLE NOZZLE CLEANER

GENERAL

The Twist-Tip nozzle cleaner allows purging of a clogged nozzle orifice without disassembly from the spray gun. The tungsten carbide nozzle is permanently assembled into the rotatable cylinder tip insert and handle assembly. No alignment or adjustments are required.

ASSEMBLY

Assembly to spray gun is simple and the exploded view is self-explanatory. The 54-2378 diffuser assembly is required to assemble the Twist-Tip into the gun.

FEATURES OF THE TWIST-TIP ATTACHMENT

- Fits most popular airless spray guns
- Low friction turning
- Equals or exceeds life of other reversible spray tips
- Hand-tightened seal system
- Assembly suitable for solvent and water-based
- Maximum working pressure: 7,500 PSI
- Rapid changing of the tip and base by hand without tools

IMPORTANT OPERATING INSTRUCTIONS

1. The spray gun must be shut off while rotating the Twist-Tip attachment handle.
2. If leakage occurs, unit must be disassembled, cleaned and parts checked for any damage. Replace damaged parts with genuine Binks parts.

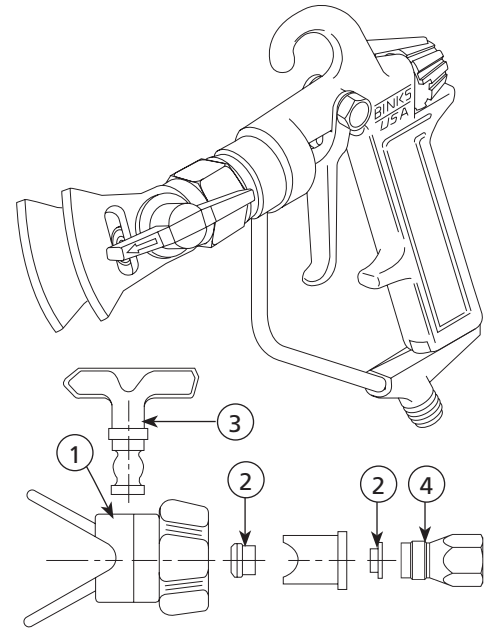

PARTS LIST

When ordering, please specify Part No.

⚠ WARNING

Do not operate unit with leakage from the spray gun, Twist-Tip attachment or hose or severe injury may result.

3. With proper care, the Twist-Tip attachment will give long, reliable service. To maintain this performance, it should be flushed with solvent or proper cleaning fluid following each spray period.

ITEM NO.	PART NO.	DESCRIPTION	QTY.
1	454-3	SAFETY GUARD ASM.....	1
1	454-5	SAFETY GUARD (G Thread) ASM ...	1
2	454-1	SEAL KIT ASSEMBLY (Part of Safety Guard)	1
3	454-Tip Size	SPRAY TIP	1
4	54-2378	DIFFUSER	1

AIRLESS TWIST TIP CHART

SURFACE	COATING	FAN WIDTH (in inches)	ORIFICE SIZE							
			.009	.011	.013	.015.017	.019	.021	.023	
Wood Interior Cabinets, Paneling	Stain, Sanding Sealer, Lacquer Varnish, Shellac, Enamels	6"	309	311	313	-	-	-	-	-
Interior Walls Ceilings, Drywall Plaster	Latex, Vinyl Acrylic	10"	-	-	-	515	517	519	-	-
		12"	-	-	-	615	617	-	-	-
Overhang	Primers, Enamels	10"	-	-	-	515	517	-	-	-
Masonry Block, Stucco, Concrete	Vinyl, Acrylic Latex, Oil Base, Alkyds	10"	-	-	-	-	517	519	521	-
Wood Exterior Shingle Siding, Shiplap	Exterior, Stains Latex, Vinyl, Acrylic	10"	-	-	-	-	517	519	521	-
Open Joist Ceiling Areas	MIL White HI Build	10"	-	-	-	-	-	519	-	-
		12"	-	-	-	-	-	-	521	523

BASE RETAINERS

Assembly Number	454-3 3/4 – 20	454-5 7/8 – 14 (G)
	Binks	Graco, Titan, Wagner

Ordering: For twist tips add the prefix 454- to size tip selected. For example, if you select 517, order as 454-517.

FLAT TIP ASSEMBLIES FOR AIRLESS GUNS

PART NUMBER	STAMPED NUMBER	ORIFICE (INCHES)	FAN WIDTH (12" FROM SURFACE)	PART NUMBER	STAMPED NUMBER	ORIFICE (INCHES)	FAN WIDTH (12" FROM SURFACE)	PART NUMBER	STAMPED NUMBER	ORIFICE (INCHES)	FAN WIDTH (12" FROM SURFACE)
9-1170	9-1170	.011	8-10	9-2140	9-2140	.021	10-12	9-3620	9-3620	.036	6-8
9-1180	9-1180	.011	10-12	9-2180	9-2180	.021	16-18	9-3640	9-3640	.036	12-14
9-1350	9-1350	.013	8-10	9-2190	9-2190	.021	18-20	9-3660	9-3660	.036	16-18
9-1360	9-1360	.013	10-12	9-2340	9-2340	.023	10-12	9-3680	9-3680	.036	18-20
9-1380	9-1380	.013	12-14	9-2640	9-2640	.026	12-14	9-4340	9-4340	.043	12-14
9-1550	9-1550	.015	8-10	9-3120	9-3120	.031	6-8	9-4380	9-4380	.043	18-20
9-1560	9-1560	.015	10-12	9-3140	9-3140	.031	12-14	9-5230	9-5230	.052	8-10
9-1590	9-1590	.015	14-16	9-3180	9-3180	.031	18-20	9-5240	9-5240	.052	12-14
9-1840	9-1840	.018	10-12					9-6230	9-6230	.062	8-10
9-1860	9-1860	.018	12-14								
9-1890	9-1890	.018	16-18								

NOTES

WARRANTY POLICY

Binks products are covered by Finishing Brands one year materials and workmanship limited warranty. The use of any parts or accessories, from a source other than Finishing Brands, will void all warranties. For specific warranty information please contact the closest Finishing Brands location listed below.

Finishing Brands reserves the right to modify equipment specifications without prior notice. DeVilbiss®, Ransburg®, BGK®, and Binks® are registered trademarks of Carlisle Fluid Technologies, Inc., dba Finishing Brands. ©2015 Carlisle Fluid Technologies, Inc., dba Finishing Brands. All rights reserved.



Binks is part of Finishing Brands, a global leader in innovative spray finishing technologies. For technical assistance or to locate an authorized distributor, contact one of our international sales and customer support locations below.

USA/Canada

www.binks.com
info@carlisleleft.com
Tel: 1-800-992-4657
Fax: 1-888-246-5732

Mexico

www.carlisleleft.com.mx
ventas@carlisleleft.com.mx
Tel: 011 52 55 5321 2300
Fax: 011 52 55 5310 4790

Brazil

www.devilbiss.com.br
vendas@carlisleleft.com.br
Tel: +55 11 5641 2776
Fax: 55 11 5641 1256

United Kingdom

www.finishingbrands.eu
info@carlisleleft.eu
Tel: +44 (0)1202 571 111
Fax: +44 (0)1202 573 488

France

www.finishingbrands.eu
info@carlisleleft.eu
Tel: +33(0)475 75 27 00
Fax: +33(0)475 75 27 59

Germany

www.finishingbrands.eu
info@carlisleleft.eu
Tel: +49 (0) 6074 403 1
Fax: +49 (0) 6074 403 281

China

www.finishingbrands.com.cn
mkt@carlisleleft.com.cn
Tel: +8621-3373 0108
Fax: +8621-3373 0308

Japan

www.ransburg.co.jp
overseas-sales@carlisleleft.co.jp
Tel: 081 45 785 6421
Fax: 081 45 785 6517

Australia

www.finishingbrands.com.au
sales@carlisleleft.com.au
Tel: +61 (0) 2 8525 7555
Fax: +61 (0) 2 8525 7500

